



**XLT 3870-TS3 Quiet Fire**  
Natural Gas or  
Liquid Propane



PO Box 9090 Wichita, KS 67277-0090  
P: 1-316-943-2751 F: 1-316-943-2769  
[www.xltovens.com](http://www.xltovens.com)



**Simple. Smart.**

## XLT 3870-TS3 Quiet Fire Gas Conveyor Oven

Are you looking for an affordable solution for your cooking needs?

**XLT AVI Hood**  
Available in all oven sizes



In our continuing pursuit of excellence in **XLT** ovens, we now produce our own, Quiet Fire™ burner. It utilizes state-of-the-art design and components to provide the ultimate in combustion, with a perfect balance between gas and combustion air. The resulting flame is pure and efficient, with lower CO2 emissions and up to 35% in fuel savings. And with our Simple Smart design, the unit needs no forced air fan, thus providing much quieter operation, while heat transfer and bake speed are improved.

### FEATURES

- The **XLT-3870-TS3 Quiet Fire** is available in three configurations, the single, the double, and the triple stack models.
- The optional front sandwich door is provided to load or unload product for different cook times.
- Both exterior AND INTERIOR exposed surfaces are made of easy cleaning stainless steel.
- **XLT™** ovens are manufactured with pride in the USA under stringent quality standards.
- Replacement parts are readily available through the **XLT** Fast Parts Program at a fraction of the cost of our competitors.
- The large removable front panel allows for easy access to oven interior, making cleaning much easier than our competitors' ovens of the same size.
- All **XLT™** ovens are 100% factory tested with a minimum 4-hour burn-in time.
- The conveyors can be set up to move either right-to-left or left-to-right.
- Industry leading limited 5-year warranty.

**XLT™** ovens are an improved combustion flue-less design and are more efficient than comparable ovens. All ducts, crumb trays, and the conveyor are readily removable for easy cleaning. An overhead ventilation hood is required. All **XLT** ovens are available with custom fitted AVI hood systems for the most efficient and comfortable ventilation package in the industry. 120 Volt electrical power does not require an expensive electrician to install, simply plug into an available outlet. The gas connections require a licensed plumber. All fuses are EXTERNALLY panel-mounted allowing easy troubleshooting.



# LAYOUT AND DIMENSIONS

TOP VIEW

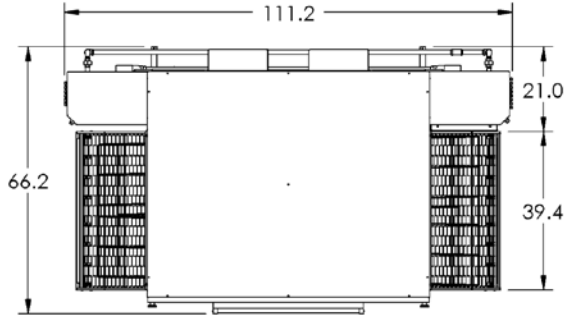

ISO VIEW  
DOUBLE STACK

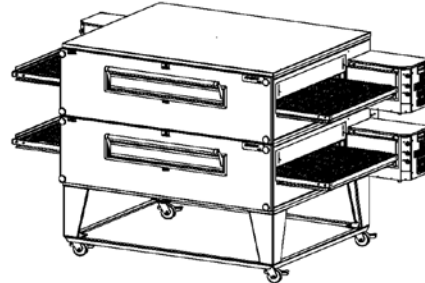

FRONT VIEW  
DOUBLE STACK

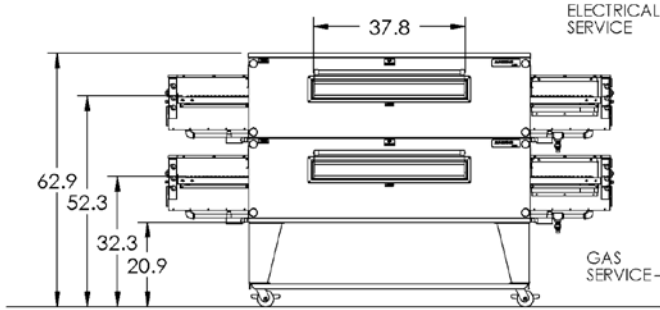

BACK VIEW  
DOUBLE STACK

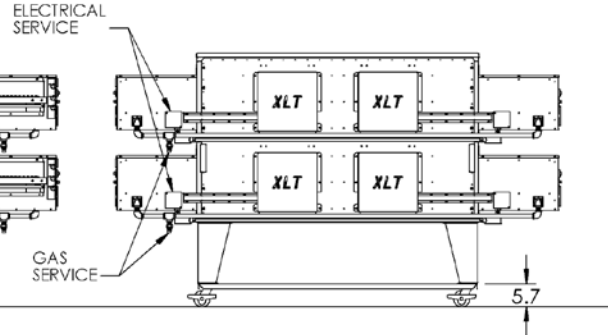

FRONT VIEW  
TRIPLE STACK

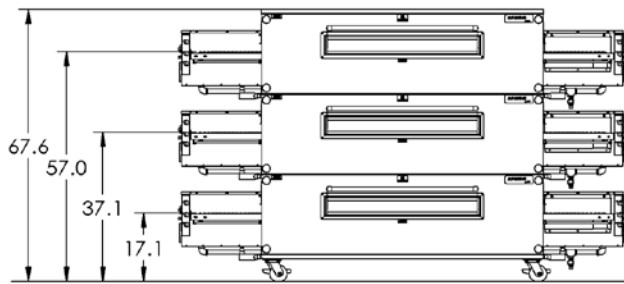

BACK VIEW  
TRIPLE STACK

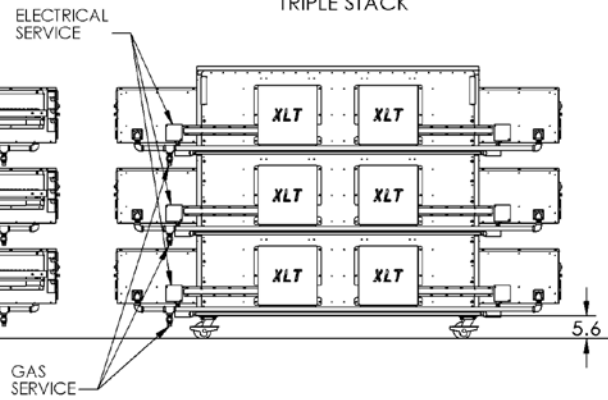

PO Box 9090  
Wichita, KS 67277-0090

P: 1-316-943-2751  
F: 1-316-943-2769  
www.xltovens.com

**XLT**  
OVENS®  
Simple. Smart.

# SPECIFICATIONS

## XLT 3870-TS3 Quiet Fire

### Electrical Requirements:

	Voltage (AC)	Phase	HZ	Amps
Single Oven	120	1	60	6.0
Double Stack	120	1	60	12.0
Triple Stack	120	1	60	18.0

### Natural Gas Requirements:

	Burner Capacity BTU/hr (Max)	Gas Supply Pressure Inches, Water Column	Gas Pipe Size (NPT)
Single Oven	160,000	8-14	1-1/2"
Double Stack	320,000	8-14	1-1/2"
Triple Stack	480,000	8-14	1-1/2"

### Or Optional Propane Gas Requirements:

	Burner Capacity BTU/hr (Max)	Gas Supply Pressure Inches, Water Column	Gas Pipe Size (NPT)
Single Oven	160,000	11.5-14	1-1/2"
Double Stack	320,000	11.5-14	1-1/2"
Triple Stack	480,000	11.5-14	1-1/2"

### General Information:

Belt Width	Bake Time Ranges*	Max Temperature	Conveyor Opening Height (Max)	Ship Weight Per Oven
38.0"	4 min-10 min	550°F	3"	1200 lbs.

\* Adjustments can be made for other bake time ranges. Specifications and dimensions are subject to change without notice. Local codes and regulations may also apply.

### Options:

- Stainless steel sandwich door handle
  - 4" conveyor opening height
  - Stainless steel handle
  - Solid fronts
  - Product shelves
  - Product slides
  - Split belts
  - Perforated crumb trays
- All **XLT** ovens available with custom fitted AVI hood systems for the most efficient and comfortable ventilation package in the industry.



**Simple. Smart.**

PO Box 9090 Wichita, KS 67277-0090  
 P: 1-316-943-2751 F: 1-316-943-2769  
[www.xltovens.com](http://www.xltovens.com)

